



Soluzioni per il trattamento dei liquidi carichi
Waste water treatment solutions

RAW FLUID MOTION



Zootecnia
Biogas
Industria
Livestock farming
Biogas
Industry



VENERONI
ADVANCED FLUID MOTION



RAW FLUID MOTION

Consentire il pompaggio e l'omogeneizzazione dei liquidi con presenza di corpi solidi o fibrosi: Veneroni offre una gamma completa di soluzioni per il trattamento dei liquidi carichi, per rispondere a qualsiasi tipo di esigenza, dalla miscelazione, travaso e distribuzione per la zootecnia e il biogas, all'applicazione in diversi processi industriali.

ZOOTECNIA

Triturazione, miscelazione, travaso e distribuzione liquami.

BIOGAS

Triturazione, miscelazione, travaso e distribuzione liquami, applicazioni di processo.

INDUSTRIA

Varie applicazioni nei settori lavorazione e confezionamento frutta e verdura, macellazione, navale, ecc.

Allowing pumping and homogenization of fluids with solid or fibrous particles: Veneroni offers a complete range of waste water treatment solutions, to meet any type of need, from mixing, transfer and distribution for livestock farming and biogas, to many applications in different industrial processes.

LIVESTOCK FARMING

Slurry chopping, mixing, transfer and distribution.

BIOGAS

Slurry chopping, mixing, transfer and distribution, different process applications.

INDUSTRY

Many applications in different sectors: processing and packaging fruit and vegetable, slaughter, shipbuilding, etc.



MOVING FORWARD

Siamo convinti che la ricerca dell'eccellenza e il continuo slancio verso l'innovazione siano parte integrante del nostro DNA. Il nostro reparto R&D è dotato di strumenti informatici all'avanguardia per il calcolo delle strutture; ogni progetto viene attentamente verificato nella nostra sala collaudo e poi testato direttamente sul campo, perché vogliamo essere sicuri di offrirvi sempre la massima qualità.

- **Software di modellazione CAD 3D**
- **Calcolo strutturale FEA**
- **Calcolo fluido-dinamico computazionale CFD**
- **Collaudo in sala prove**

We believe that the pursuit of excellence and the continuous drive towards innovation are an integral part of our DNA. Our R&D department is equipped with state-of-the-art IT tools for structural analysis; all our projects are carefully checked in our testing room and then tested directly on the field, because we want to be sure to offer you the highest quality.

- **3D CAD modeling software**
- **FEA structural analysis**
- **CFD Computational Fluid Dynamics analysis**
- **Full inspection in Testing Room**

Calcolo FEA
FEA analysis

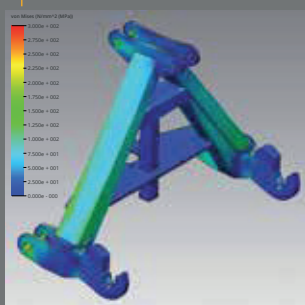

Calcolo CFD
CFD analysis

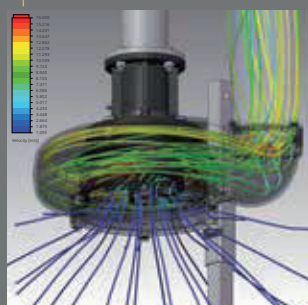

Sala prove
Testing Room



POMPE TRITURATRICI

CHOPPER PUMPS



Corpo pompa in ghisa sferoidale GS 400, sistema di triturazione con doppio disco di rasamento in acciaio temprato.

Estrema protezione contro la corrosione e l'usura anche in presenza di liquami abrasivi, massima affidabilità contro l'attorcigliamento delle fibre lunghe, manutenzione semplice ed estremamente ridotta.

Pump body made of spheroidal cast iron GS 400, chopping system with double shim disc made of hardened steel.

Extreme protection against corrosion and wear even with abrasive slurry, maximum reliability against twisting of long fibers, simple and extremely low maintenance.



Trasmissione in bagno d'olio con tenuta meccanica al widia-widia e albero in AISI 304.

Massima protezione degli organi di trasmissione dal contatto con il liquido pompato e dal funzionamento accidentale a secco, estrema durata dei componenti.

Oil bath transmission with widia-widia mechanical seal and AISI 304 shaft.

Maximum protection of the transmission parts from contact with the pumped liquid and from accidental dry operation, extreme durability of the parts.



Elica di miscelazione in AISI 304 per un'accurata miscelazione localizzata nell'area di pompaggio [LVTM | LVEM].

Componenti appositamente progettati per ottimizzare l'efficacia del prodotto e valorizzarne le caratteristiche.

AISI 304 mixing propeller for accurate localized mixing in the pumping area [LVTM | LVEM].

Parts specifically designed to optimize product's effectiveness and enhance its features.



Carpenteria zincata a caldo.

Alta resistenza alla corrosione e agli agenti abrasivi.

Carpenteria in acciaio inossidabile AISI 304.

Estrema resistenza alla corrosione e agli agenti abrasivi per la massima durata nel tempo.

Hot galvanized carpentry.

High resistance to corrosion and abrasive agents.

AISI 304 stainless steel carpentry.

Extreme resistance to corrosion and abrasive agents for long durability.

Disposte a fare il lavoro sporco

Ready to do the dirty work



LVT

Pompa verticale a trattore Tractor driven vertical pump



La pompa LVT offre le massime prestazioni della gamma sfruttando la forza motrice del trattore. Dotata di ugello di miscelazione orientabile, consente un'efficace omogeneizzazione delle sedimentazioni presenti nel liquido da trattare. Il carrello, disponibile come accessorio, permette il posizionamento in più punti garantendo notevole versatilità. La pompa LVT è disponibile anche nella versione P senza ugello di miscelazione, e nella versione S con attuatore idraulico della valvola dell'ugello di miscelazione.

LVT pump offers the highest performance of the range by exploiting tractor's power. Equipped with an adjustable mixing nozzle, it allows an effective homogenization of sedimentation present in the liquid to be handled. The trolley, available as an accessory, enables moving up granting great versatility. LVT pump is also available in the version P without mixing nozzle, and in the version S with hydraulic actuator of the mixing nozzle valve.



CARATTERISTICHE | FEATURES

Modello Model	Giri/Min - RPM		P Max [kW]	Q [l/s]													
	PTO	Pompa Pump		25	40	55	70	85	100	115	130	145	160	175	190		
LVT 12	540	1600	40	Q [l/min]	1500	2400	3300	4200	5100	6000	6900	7800	8700	9600	10500	11400	
				Q [mc/h]	90	144	198	252	306	360	414	468	522	576	630	684	
LVT 15	540	1600	60	P [kW]	14,5	14,8	15,2	16	17,5	19,5							
				H [m]	23	21	19	16	13	9							
LVT 15	900	1800	80	P [kW]	28	29	29	30	30	32	34	37	40				
				H [m]	31	29	27	25	23	20	17	14	11				
LVT 20	1000	2000	100	P [kW]		40	41	42	42	42	43	45	48	52			
				H [m]		37	35	33	30	27	24	21	17	13			
LVT 20	1000	2000	100	P [kW]			54	55	56	57	58	61	64	67	71	75	
				H [m]			43	41	38	35	32	29	25	21	17	13	

DIMENSIONI | DIMENSIONS

Modello Model	D [mm]	Lunghez. Lenght [m]	H [m]	A [mm]	B [mm]	C [mm]	E [mm]	Peso Weight [kg]
LVT 12	120	2	1,3 ÷ 1,8	2360	2590	520	710	190
		2,5	1,8 ÷ 2,3	2860	3090		860	200
		3	2,3 ÷ 2,8	3360	3590		1010	210
		3,5	2,8 ÷ 3,3	3860	4090		1160	220
		4	3,3 ÷ 3,8	4360	4590		1310	230
		4,5	3,8 ÷ 4,3	4860	5090		1460	240
LVT 15	150	2	1,3 ÷ 1,8	2310	2550	580	720	220
		2,5	1,8 ÷ 2,3	2810	3050		870	230
		3	2,3 ÷ 2,8	3310	3550		1020	240
		3,5	2,8 ÷ 3,3	3810	4050		1170	250
		4	3,3 ÷ 3,8	4310	4550		1320	265
		4,5	3,8 ÷ 4,3	4810	5050		1470	275
LVT 20	200	2	1,3 ÷ 1,8	2310	2590	605	900	220
		2,5	1,8 ÷ 2,3	2810	3090		900	235
		3	2,3 ÷ 2,8	3310	3590		1020	250
		3,5	2,8 ÷ 3,3	3810	4090		1170	265
		4	3,3 ÷ 3,8	4310	4590		1320	280
		4,5	3,8 ÷ 4,3	4810	5090		1470	295
		5	4,3 ÷ 4,8	5310	5590		1620	310

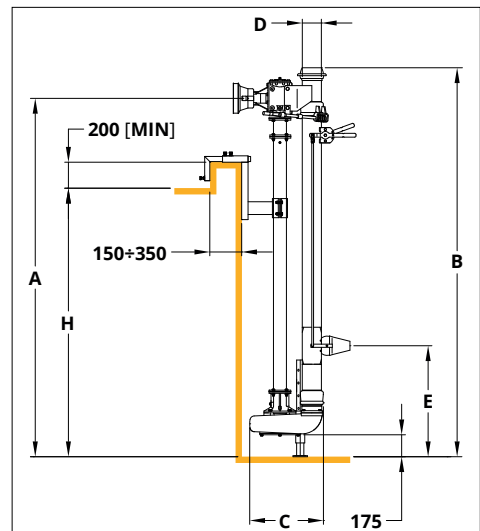

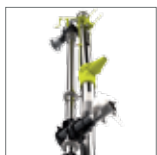

La pompa LVTM offre le massime prestazioni della gamma sfruttando la forza motrice del trattore. Oltre ad essere dotata di ugello di miscelazione orientabile, si caratterizza per la presenza di un'elica di miscelazione che consente l'omogeneizzazione costante anche durante il pompaggio. Il carrello, disponibile come accessorio, permette il posizionamento in più punti garantendo notevole versatilità. La pompa LVTM è disponibile anche nella versione P senza ugello di miscelazione, e nella versione S con attuatore idraulico della valvola dell'ugello di miscelazione.

LVTM pump offers the highest performance of the range by exploiting tractor's power. Besides being equipped with an adjustable mixing nozzle, it is characterized by the presence of a mixing propeller which allows homogenization even while pumping. The trolley, available as an accessory, enables moving up granting great versatility. LVTM pump is also available in the version P without mixing nozzle, and in the version S with hydraulic actuator of the mixing nozzle valve.



CARATTERISTICHE | FEATURES

Modello Model	Giri/Min - RPM		P Max [kW]	Q [l/s]												Mixer	
	PTO	Pompa Pump		25	40	55	70	85	100	115	130	145	160	RPM	Q [mc/h]		
LVTM 12	540	1600	50	Q [l/min]	1500	2400	3300	4200	5100	6000	6900	7800	8700	9600	830	600	
				Q [mc/h]	90	144	198	252	306	360	414	468	522	576			
LVTM 15	540	1600	75	P [kW]	21,5	21,8	22,2	23	24,5	26,5					770	850	
				H [m]	23	21	19	16	13	9							
LVTM 15	900	1800	95	P [kW]		53	54	55	55	56	58	61	65	69	870	900	
				H [m]		37	35	33	30	27	24	21	17	13			

DIMENSIONI | DIMENSIONS

Modello Model	D [mm]	Lunghez. Lenght [m]	H [m]	A [mm]	B [mm]	C [mm]	E [mm]	F [mm]	Peso Weight [kg]
LVTM 12	120	2	1,3 ÷ 1,8	2375	2610	620	1650	960	225
		2,5	1,8 ÷ 2,3	2875	3110		1650		235
		3	2,3 ÷ 2,8	3375	3610		1650		245
		3,5	2,8 ÷ 3,3	3875	4110		1950		255
		4	3,3 ÷ 3,8	4375	4610		1950		265
		4,5	3,8 ÷ 4,3	4875	5110		2250		280
LVTM 15	150	2	1,3 ÷ 1,8	2310	2550	650	1670	1030	290
		2,5	1,8 ÷ 2,3	2810	3050		1670		310
		3	2,3 ÷ 2,8	3310	3550		1670		320
		3,5	2,8 ÷ 3,3	3810	4050		1980		330
		4	3,3 ÷ 3,8	4310	4550		1980		345
		4,5	3,8 ÷ 4,3	4810	5050		2280		355
		5	4,3 ÷ 4,8	5310	5550		2280		370

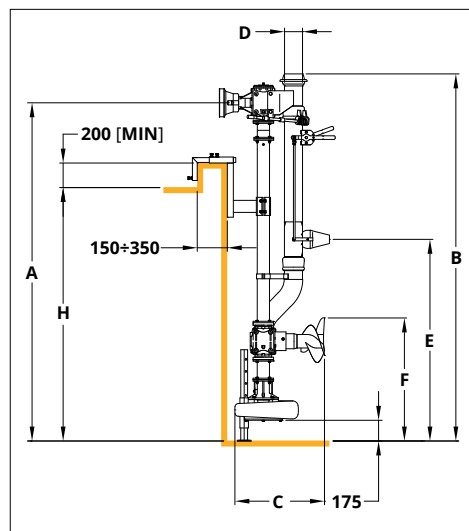

LVE

Pompa verticale elettrica Electric vertical pump



La pompa LVE offre elevate prestazioni anche con modeste potenze applicate e in presenza di liquami densi contenenti corpi solidi e fibrosi. L'azionamento con motore elettrico garantisce notevole praticità, permettendo di automatizzare il funzionamento della pompa e la gestione dell'intero impianto. Dotata di ugello di miscelazione orientabile, consente un'efficace omogeneizzazione delle sedimentazioni presenti del liquidi da trattare. La pompa LVE è disponibile anche nella versione P senza ugello di miscelazione, e nella versione S con attuatore pneumatico della valvola dell'ugello di miscelazione.

LVE pump offers high performance even with moderate applied power and in the presence of thick sewage containing solid and fibrous matters. Electric motor drive grants remarkable ease of use, allowing to automate pump's operation and the management of the whole system. Equipped with an adjustable mixing nozzle, it allows an effective homogenization of sedimentation present in the liquids to be handled. LVE pump is also available in the version P without mixing nozzle, and in the version S with pneumatic actuator of the mixing nozzle valve.



CARATTERISTICHE | FEATURES

Modello Model	Giri/Min RPM	P [kW]	Q [l/s]	10	25	40	55	70	85	100	115
			Q [l/min]	600	1500	2400	3300	4200	5100	6000	6900
			Q [mc/h]	36	90	144	198	252	306	360	414
LVE 10	1450	4	P [kW]	2,9	3,2						
			H [m]	9	7						
	1450	5,5	P [kW]	3,4	3,4	3,9					
			H [m]	12	10	7					
LVE 12	1450	7,5	P [kW]	5,5	5,6	6	6,5				
			H [m]	11	10	8	6				
	1450	9,2	P [kW]	6,5	6,7	7	7,5				
			H [m]	12	11	9	7				
	1450	11	P [kW]	8	8,2	8,5	9	9,8			
			H [m]	15	13	11	9	7			
	1450	15	P [kW]	11	11,2	11,4	11,8	12,6	13,4		
			H [m]	20	18	16	13	10	7		
LVE 15	1450	18,5	P [kW]	14,6	14,7	14,8	14,8	14,9	15,7		
			H [m]	19	18	16	14	13	10		
	1450	22	P [kW]	16,3	16,6	16,7	16,7	17	17,8	19,2	
			H [m]	20	19	18	16	14	12	10	
	1450	30	P [kW]	21,6	21,8	22	22,3	22,8	23,6	25	26,4
			H [m]	25	24	23	21	19	17	15	13

DIMENSIONI | DIMENSIONS

Modello Model	P [kW]	D [mm]	Lunghez. Length [m]	H [m]	A [mm]	B Max [mm]	C [mm]	E [mm]	Peso Weight [kg]
LVE 10	4 5,5	100	2	1,3 ÷ 1,8	2090	2600	440	660	120
			2,5	1,8 ÷ 2,3	2590	3100		810	130
			3	2,3 ÷ 2,8	3090	3600		960	140
			3,5	2,8 ÷ 3,3	3590	4100		1110	150
			4	3,3 ÷ 3,8	4090	4600		1260	160
			4,5	3,8 ÷ 4,3	4590	5100		1410	170
LVE 12	7,5 9,2 11 15	120	2	1,3 ÷ 1,8	2200	2940	520	710	190
			2,5	1,8 ÷ 2,3	2700	3440		860	200
			3	2,3 ÷ 2,8	3200	3940		1010	210
			3,5	2,8 ÷ 3,3	3700	4440		1160	220
			4	3,3 ÷ 3,8	4200	4940		1310	230
			4,5	3,8 ÷ 4,3	4700	5440		1460	240
LVE 15	18,5 22 30	150	2	1,3 ÷ 1,8	2230	3110	580	720	210
			2,5	1,8 ÷ 2,3	2730	3610		870	220
			3	2,3 ÷ 2,8	3230	4110		1020	230
			3,5	2,8 ÷ 3,3	3730	4610		1170	240
			4	3,3 ÷ 3,8	4230	5110		1320	250
			4,5	3,8 ÷ 4,3	4730	5610		1470	260
			5	4,3 ÷ 4,8	5230	6110		1620	270

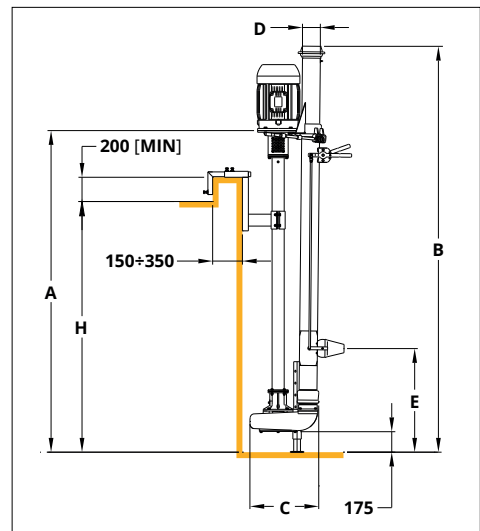



La pompa LVEM offre elevate prestazioni anche con modeste potenze applicate e in presenza di liquami densi contenenti corpi solidi e fibrosi. L'azionamento con motore elettrico garantisce notevole praticità, permettendo di automatizzare il funzionamento della pompa e la gestione dell'intero impianto. Oltre ad essere dotata di ugello di miscelazione orientabile, si caratterizza per la presenza di un'elica di miscelazione che consente l'omogeneizzazione costante anche durante il pompaggio. La pompa LVEM è disponibile anche nella versione P senza ugello di miscelazione, e nella versione S con attuatore pneumatico della valvola dell'ugello di miscelazione.

LVEM pump offers high performance even with moderate applied power and in the presence of thick sewage containing solid and fibrous matters. Electric motor drive grants remarkable ease of use, allowing to automate pump's operation and the management of the whole system. Besides being equipped with an adjustable mixing nozzle, it is characterized by the presence of a mixing propeller which allows homogenization even while pumping. LVEM pump is also available in the version P without mixing nozzle, and in the version S with pneumatic actuator of the mixing nozzle valve.



CARATTERISTICHE | FEATURES

Modello Model	Giri/Min RPM	P [kW]	Q [l/s]	10	25	40	55	70	85	100	Mixer Q [mc/h]		
			Q [l/min]	600	1500	2400	3300	4200	5100	6000			
			Q [mc/h]	36	90	144	198	252	306	360			
LVEM 10	1450	9,2	P [kW]	6,9	6,9	7,4					250		
			H [m]	12	10	7							
LVEM 12	1450	11	P [kW]	9	9,1	9,5	10				250		
			H [m]	11	10	8	6						
		15	P [kW]	11,5	11,7	12	12,5	13,3					
			H [m]	15	13	11	9	7					
		18,5	P [kW]	14,5	14,7	14,9	15,3	16,1	16,9				
			H [m]	20	18	16	13	10	7				
LVEM 15	1450	22	P [kW]	18,1	18,2	18,3	18,3	18,4	19,2		250		
			H [m]	19	18	16	14	13	10				
		30	P [kW]	23,8	24,1	24,2	24,2	24,5	25,3	26,7			
			H [m]	20	19	18	16	14	12	10			
													550

DIMENSIONI | DIMENSIONS

Modello Model	P [kW]	D [mm]	Lunghez. Lenght [m]	H [m]	A [mm]	B Max [mm]	C [mm]	E [mm]	F [mm]	Peso Weight [kg]
LVEM 10	9,2	100	2	1,3 + 1,8	2090	2700	580	1250	870	160
			2,5	1,8 + 2,3	2590	3200		1250		170
			3	2,3 + 2,8	3090	3700		1250		180
			3,5	2,8 + 3,3	3590	4200		1450		190
			4	3,3 + 3,8	4090	4700		1650		200
			4,5	3,8 + 4,3	4590	5200		1850		210
LVEM 12	11 15 18,5	120	2	1,3 + 1,8	2200	3040	620	1390	940	230
			2,5	1,8 + 2,3	2700	3540		1390		240
			3	2,3 + 2,8	3200	4040		1390		250
			3,5	2,8 + 3,3	3700	4540		1590		260
			4	3,3 + 3,8	4200	5040		1790		270
			4,5	3,8 + 4,3	4700	5540		1990		280
LVEM 15	22 30	150	2	1,3 + 1,8	2230	3110	650	1400	965	250
			2,5	1,8 + 2,3	2730	3610		1400		260
			3	2,3 + 2,8	3230	4110		1400		270
			3,5	2,8 + 3,3	3730	4610		1600		280
			4	3,3 + 3,8	4230	5110		1800		290
			4,5	3,8 + 4,3	4730	5610		2000		300
			5	4,3 + 4,8	5230	6110	2200		310	

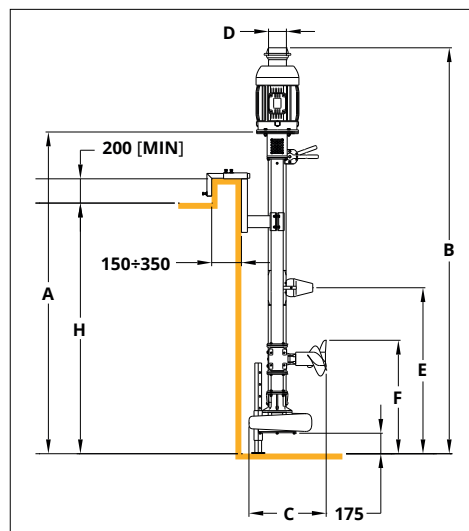

LSI

Pompa sommersibile idraulica
Hydraulic submersible pump



La pompa LSI offre un'elevata efficienza e notevole versatilità grazie al funzionamento tramite motore idraulico.

Il motore idraulico sommersibile, azionato dall'impianto idraulico della macchina operatrice, permette svariate applicazioni mantenendo estremamente compatte le dimensioni della pompa.

*LSI pump offers high efficiency and great versatility thanks to hydraulic motor drive.
The submersible hydraulic motor, powered by the hydraulic system of the operating machine, allows various applications keeping the dimensions of the pump extremely compact.*



CARATTERISTICHE | *FEATURES*

Modello Model	P [kW]	Giri/Min RPM	Portata Flow [l/min]	P Max Cont. [bar]	ΔP Cont. [bar]	Q [l/s]								
						10	25	40	55	70	85	100	115	
LSI 12	15	1480	66	220	160	Q [l/min]	600	1500	2400	3300	4200	5100	6000	6900
						Q [mc/h]	36	90	144	198	252	306	360	414
						P [kW]	11	11,2	11,4	11,8	12,6	13,4		
LSI 15	30	1480	122	250	180	H [m]	20	18	16	13	10	7		
						P [kW]	21,6	21,8	22	22,3	22,8	23,6	25	26,4
						H [m]	25	24	23	21	19	17	15	13

DIMENSIONI | *DIMENSIONS*

Modello Model	P [kW]	D [mm]	A [mm]	C [mm]	Peso Weight [kg]
LSI 12	15	120	620	520	150
LSI 15	30	150	610	580	180

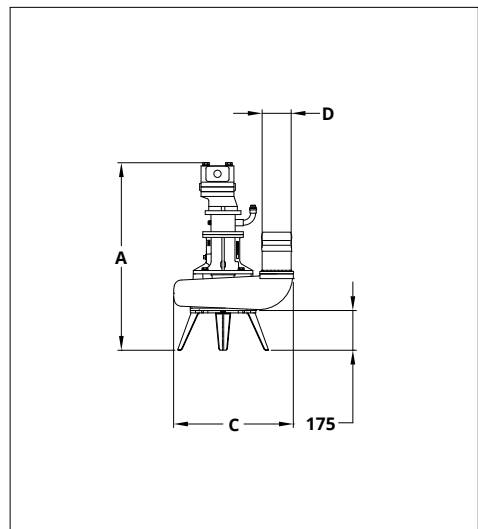



La pompa LSE garantisce elevate prestazioni anche con modeste potenze applicate e offre notevole praticità grazie alle dimensioni compatte. Il motore elettrico sommersibile, progettato per l'impiego in liquidi aggressivi ed estremamente affidabile, presenta il grande vantaggio di poter installare la pompa in vasche chiuse o difficilmente accessibili da pompe verticali.

LSE pump grants high performance even with moderate applied power and it offers remarkable practicality thanks to compact dimensions. The submersible electric motor, designed to be used into aggressive liquids and extremely reliable, has the great advantage to allow pump's installation in closed tanks or where it would be difficult to use vertical pumps.



CARATTERISTICHE | FEATURES

Modello Model	Giri/Min RPM	P [kW]	Q [l/s]	10	25	40	55	70	85	100
			Q [l/min]	600	1500	2400	3300	4200	5100	6000
			Q [mc/h]	36	90	144	198	252	306	360
LSE 10	1450	5,5	P [kW]	3,4	3,4	3,9				
			H [m]	12	10	7				
LSE 12	1450	7,5	P [kW]	5,5	5,6	6	6,5			
			H [m]	11	10	8	6			
		11	P [kW]	8	8,2	8,5	9	9,8		
			H [m]	15	13	11	9	7		
		15	P [kW]	11	11,2	11,4	11,8	12,6	13,4	
			H [m]	20	18	16	13	10	7	
LSE 15	1450	22	P [kW]	16,3	16,6	16,7	16,7	17	17,8	19,2
			H [m]	20	19	18	16	14	12	10

DIMENSIONI | DIMENSIONS

Modello Model	P [kW]	D [mm]	A [mm]	C [mm]	Peso Weight [kg]
LSE 10	5,5	100	820	440	110
LSE 12	7,5	120	810	520	120
	11		950		150
	15		1120		230
LSE 15	22	150	1170	580	290

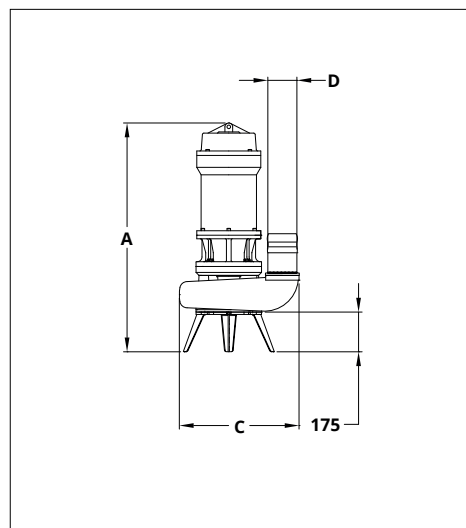

RKT

Pompa di superficie per trattore con moltiplicatore Surface pump for tractor with overgear

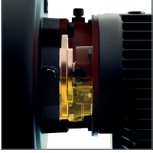
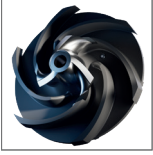

La nuova pompa RKT è stata concepita e progettata per superare i limiti dei prodotti attualmente utilizzati nei sistemi di distribuzione dei reflui zootecnici. La sua innovativa idraulica garantisce elevate prestazioni con costi operativi minimi, anche quando si affrontano liquidi densi e fibrosi, grazie al miglior rendimento idraulico nella sua categoria e a un sistema di triturazione innovativo ed efficace. Ogni componente della pompa RKT è stato attentamente studiato e dimensionato per resistere alle condizioni di lavoro più gravose, garantendo massima affidabilità e durata, il tutto mantenendo la semplicità costruttiva, che è una caratteristica fondamentale della nostra filosofia.

The new RKT pump has been conceived and designed to overcome the limits of the products currently used in livestock waste distribution systems. The new innovative pump design guarantees high performance with minimal operating costs, even when dealing with dense and fibrous liquids, thanks to the best hydraulic efficiency in its category and an innovative and effective chopping system. Each component of the RKT pump has been carefully designed and dimensioned to withstand the most demanding working conditions, ensuring maximum reliability and durability, even maintaining the simplicity of construction, which is a key feature of our philosophy.



CARATTERISTICHE | FEATURES

Modello Type	Moltiplicatore Overgear	Giri PTO PTO rpm	Pompa Pump	I/s	8	17	25	33	42	50	58	67	75	83	92	Potenza trattore Tractor Power [kW]
				l/min	m ³ /h	US gpm	Imp gpm	Hm [m]	P [kW]	Hm [m]	P [kW]	Hm [m]	P [kW]	Hm [m]	P [kW]	
RKT 100-H1	1:3,41	850	2900	Hm [m]		136	135	132	128	123	117	109	100	90	79	135
				P [kW]		69	74	78	83	88	94	100	106	112	119	
		810	2750	Hm [m]	122	122	121	118	114	109	103	95	86	76		120
				P [kW]	59	63	67	71	76	81	86	92	98	104		
		730	2500	Hm [m]	105	105	103	101	97	91	85	77	68	57		105
				P [kW]	51	54	58	62	67	72	77	82	88	94		
		640	2175	Hm [m]	76	76	74	71	67	61	55	46	37			80
				P [kW]	38	41	44	48	52	56	61	66	71			

Pos.	Codice Code	Descrizione Description
1	RKT001	RKT 100-H1
2	G08-0130	Telaio Frame
3	G16-0104	Aspirazione Inlet
4	G21-0039	Mandata 135° Outlet 135°
5	163-0015	Giunto sferico Ferrari Ferrari ball coupling
6	159-0068	Sistema DSS DSS Device
7	159-0075	Sistema di adescamento Priming system

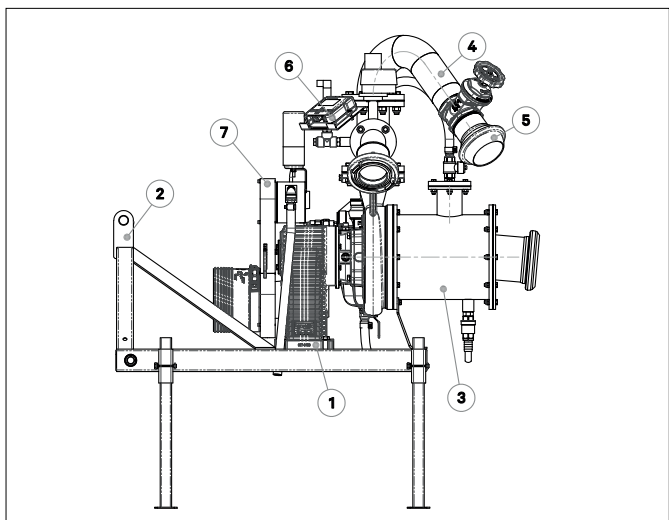



La pompa LKE garantisce elevate prestazioni anche con modeste potenze applicate nella gestione dei reflui degli impianti di processo. La pompa con tenuta meccanica presenta il vantaggio di poter essere installata in camera asciutta sia in posizione verticale che orizzontale.

LKE pump grants high performance even with moderate applied power in the handling of wastewater in process plants. The pump with mechanical seal has the advantage to allow pump's installation in dry room both vertically and horizontally.



CARATTERISTICHE | FEATURES

Modello Model	Giri/Min RPM	P [kW]	Q [l/s]	10	25	40	55	70	85	100	115
			Q [l/min]	600	1500	2400	3300	4200	5100	6000	6900
			Q [mc/h]	36	90	144	198	252	306	360	414
LKE 10	1450	4	P [kW]	2,9	3,2						
			H [m]	9	7						
		5,5	P [kW]	3,4	3,4	3,9					
LKE 12	1450	7,5	H [m]	12	10	7					
			P [kW]	5,5	5,6	6	6,5				
		11	H [m]	11	10	8	6				
			P [kW]	8	8,2	8,5	9	9,8			
		15	H [m]	15	13	11	9	7			
			P [kW]	11	11,2	11,4	11,8	12,6	13,4		
LKE 15	1450	18,5	H [m]	20	18	16	13	10			
			P [kW]	14,6	14,7	14,8	14,8	14,9	15,7		
		22	H [m]	19	18	16	14	13	10		
			P [kW]	16,3	16,6	16,7	16,7	17	17,8	19,2	
		30	H [m]	20	19	18	16	14	12	10	
			P [kW]	21,6	21,8	22	22,3	22,8	23,6	25	26,4
		H [m]	25	24	23	21	19	17	15	13	

DIMENSIONI | DIMENSIONS

Modello Model	D1 [mm]	D2 [mm]	P [kW]	A [mm]	B [mm]	C [mm]	Peso Weight [kg]
LKE 10	150-PN10	100-PN10	4	935	365	800	135
			5,5	1000			140
			7,5	1180			190
LKE 12	150-PN10	120-PN10	11	1280	415	1040	210
			15	1340			250
			18,5	1395			340
LKE 15	200-PN10	150-PN10	22	1435	430	1040	360
			30	1465			440

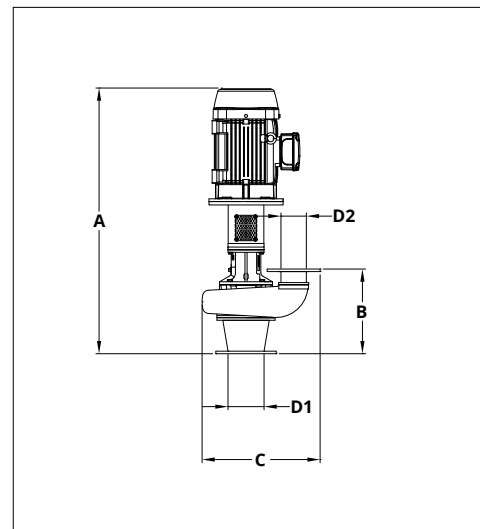

MISCELATORI

MIXERS



Elica di miscelazione con profilo autopulente.

Elevate prestazioni grazie alla particolare conformazione idraulica e massima affidabilità anche in presenza di fibre lunghe.

Mixing propeller with self-cleaning outline.

High performance thanks to its particular hydraulic structure and maximum reliability even with long fibers.



Trasmissione in bagno d'olio con tenuta meccanica al widia-widia.

Estrema protezione degli organi di trasmissione dal contatto con il liquido pompato e dal funzionamento accidentale a secco, massima durata dei componenti.

Oil bath transmission with widia-widia mechanical seal.

Extreme protection of the transmission parts from contact with the pumped liquid and from accidental dry operation, maximum durability of the parts.



Telaio accuratamente dimensionato per la massima estensione e per le sollecitazioni più gravose.

Componenti appositamente progettati per ottimizzare l'efficacia del prodotto e valorizzarne le caratteristiche.

Frame carefully sized for maximum extension and for the most demanding stress.

Parts specifically designed to optimize product's effectiveness and enhance its features.

Il giusto mix tra tecnologia e semplicità

The right mix of technology and simplicity



MBN

Miscelatore a trattore con struttura tubolare Tractor driven mixer with tube frame

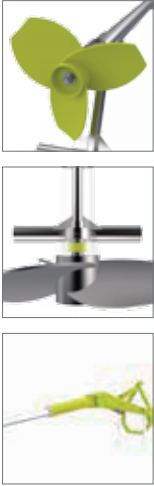

Il miscelatore MBN offre elevate prestazioni e notevole versatilità sfruttando la forza motrice del trattore. Caratterizzato da una struttura solida ma snella, è progettato per l'omogeneizzazione del liquame in vasche interrate, anche difficilmente accessibili, laddove siano presenti corpi solidi e fibrosi.

MBN mixer offers high performance and great versatility by exploiting tractor's power. Characterized by a solid but streamlined structure, it is designed for slurry homogenization in underground tanks, even accessible with difficulty, containing solid and fibrous matters.

CARATTERISTICHE | FEATURES

Modello Model	Giri/Min RPM	P Max [kW]	Q [mc/h]	D [mm]	Telaio Frame [m]	H [m]	A [mm]	B Max [mm]	Peso Weight [kg]
MBN	540	30÷60	300÷700	600	4	2,5	3800	1700	170
					5	3,5	4800	2400	200
					6	4,5	5800	3100	220

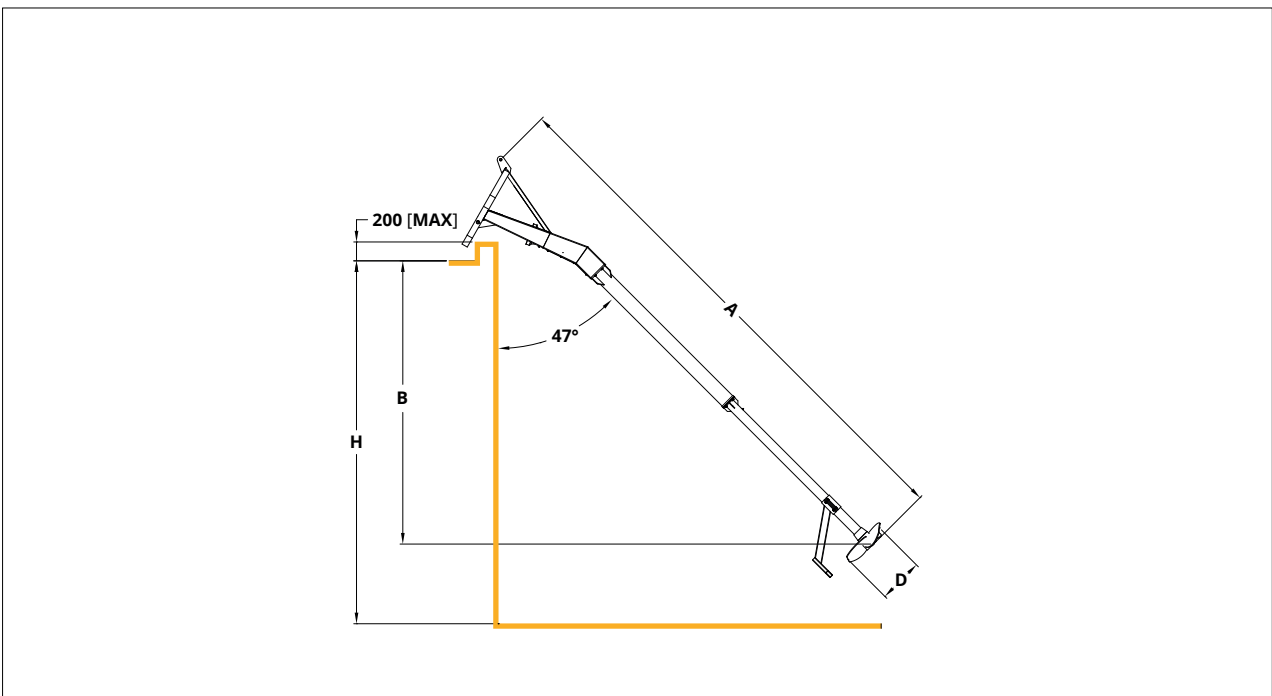

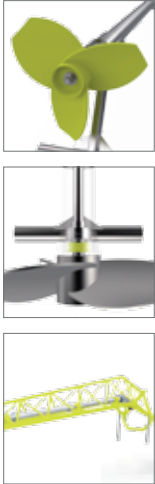

Il miscelatore MBT, azionato dalla forza motrice del trattore e progettato per vasche interrato, si caratterizza per la sua robusta struttura, pensata per la miscelazione di vasche profonde e grandi bacini di stoccaggio.

MBT mixer, driven by tractor's power and designed for underground tanks, is characterized by its sturdy structure, meant to mix slurry in deep tanks and in big storage tanks.

CARATTERISTICHE | FEATURES

Modello Model	Giri/Min RPM	P Max [kW]	Q [mc/h]	D [mm]	Telaio Frame [m]	H [m]	A [mm]	B Max [mm]	Peso Weight [kg]
MBT	540	30÷60	300÷700	600	8	5,5	8200	4700	450
					9	6,5	9200	5400	470

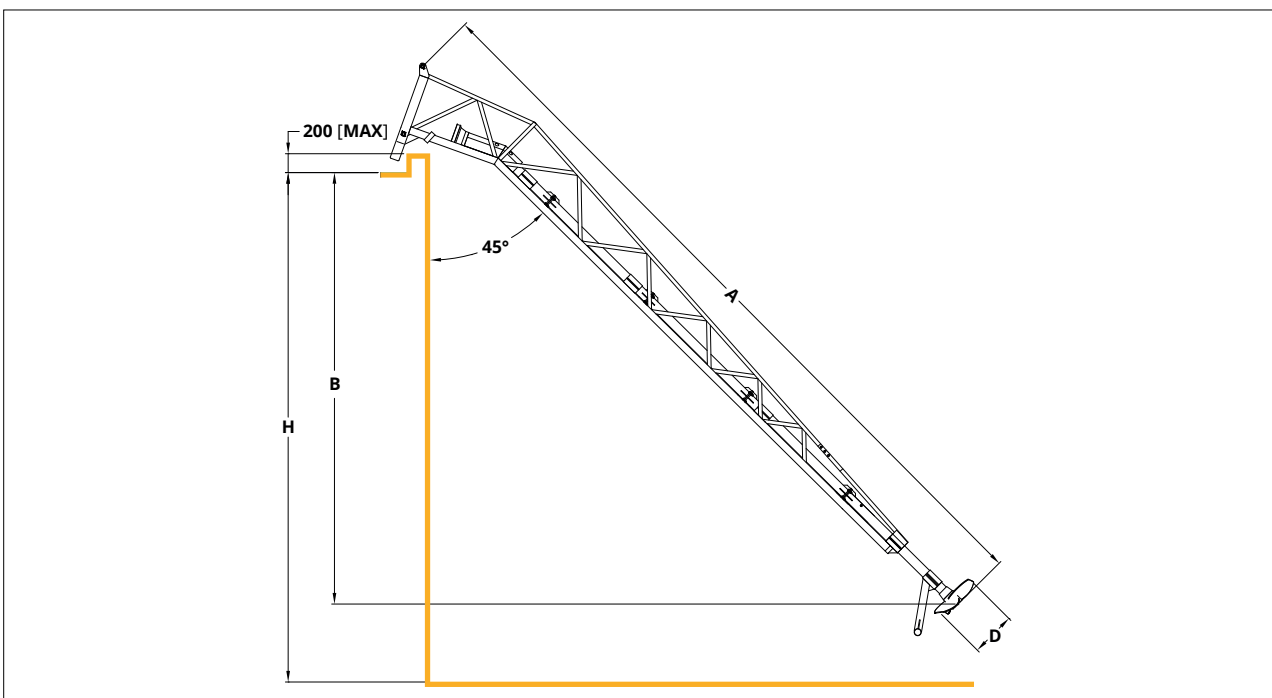

MFN

Miscelatore a trattore a colonna Tractor driven mixer with column

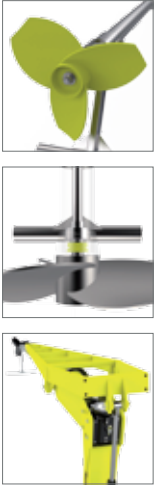

Il miscelatore MFN unisce nella sua struttura robustezza e praticità: composto da una colonna a sezione quadrata e da un braccio regolabile idraulicamente, consente l'omogeneizzazione del liquame in vasche sopraelevate; l'azionamento a trattore garantisce massima potenza e versatilità.

MFN mixer combines in its structure both sturdiness and ease of use: made up of a square column and a hydraulically adjustable arm, it allows slurry homogenization in above-ground tanks; tractor drive grants full power and versatility.

CARATTERISTICHE | FEATURES

Modello Model	Giri/Min RPM	P Max [kW]	Q [mc/h]	D [mm]	C [mm]	H1 Max [m]	Braccio Arm [m]	H2 [m]	A [mm]	B Max [mm]	Peso Weight [kg]
MFN 2	540	30÷60	300÷700	600	2300	2	6	4,2	6200	3200	630
							7	4,7	7200	3800	710
							8	5,2	8200	4400	730
MFN 2,5	540	30÷60	300÷700	600	2800	2,5	6	4,2	6200	3200	650
							7	4,7	7200	3800	700
							8	5,2	8200	4400	750
MFN 3	540	30÷60	300÷700	600	3300	3	6	4,2	6200	3200	730
							7	4,7	7200	3800	750
							8	5,2	8200	4400	770
MFN 3,5	540	30÷60	300÷700	600	3800	3,5	6	4,2	6200	3200	770
							7	4,7	7200	3800	800
							8	5,2	8200	4400	820
MFN 4	540	30÷60	300÷700	600	4300	4	7	4,7	7200	3700	820
							8	5,2	8200	4400	840
MFN 4,5	540	30÷60	300÷700	600	4800	4,5	7	4,7	7200	3800	840
							8	5,2	8200	4400	860
MFN 5	540	30÷60	300÷700	600	5300	5	8	5,7	8200	4400	880
MFN 5,5	540	30÷60	300÷700	600	5800	5,5	8	5,7	8200	4400	900
MFN 6	540	30÷60	300÷700	600	6300	6	8	5,2	8200	4400	940

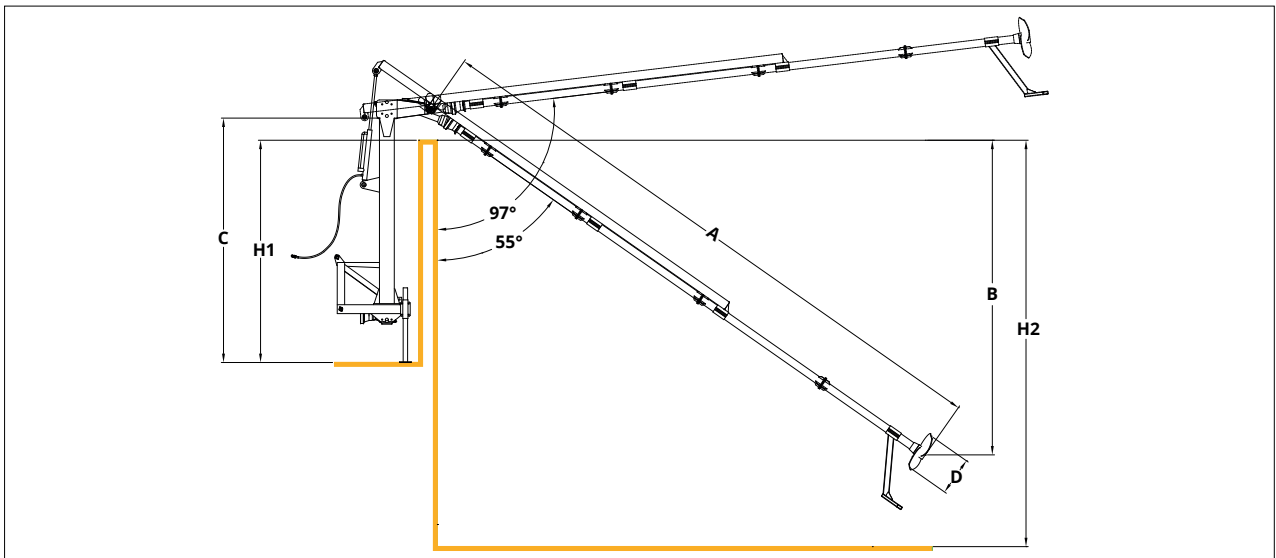

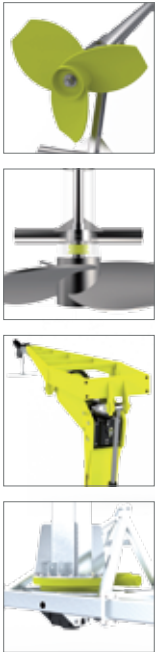

Il miscelatore MFR, permette l'omogeneizzazione del liquame in vasche sopraelevate; offre notevole solidità e flessibilità sfruttando la forza motrice del trattore, anche in presenza di liquami densi contenenti corpi solidi e fibrosi. Oltre ad essere dotato di un braccio regolabile idraulicamente, si caratterizza per la possibilità di ruotare idraulicamente anche la colonna, per una maggiore praticità di utilizzo in mancanza di spazi di manovra.

MFR mixer allows slurry homogenization in above-ground tanks; it offers great sturdiness and flexibility by exploiting tractor's power, even in the presence of thick sewage containing solid and fibrous matters. Besides being equipped with a hydraulically adjustable arm, it is characterized by a column that can be hydraulically turned for a better ease of use in absence of operating space.

CARATTERISTICHE | FEATURES

Modello Model	Giri/Min RPM	P Max [kW]	Q [mc/h]	D [mm]	H1 Max [m]	C [mm]	Braccio Arm [m]	H2 [m]	A [mm]	B Max [mm]	Peso Weight [kg]
MFR 2	540	30÷60	300÷700	600	2	2380	6	4,2	6200	3120	725
							7	4,7	7200	3720	805
							8	5,2	8200	4320	825
MFR 2,5	540	30÷60	300÷700	600	2,5	2880	6	4,2	6200	3120	745
							7	4,7	7200	3720	795
							8	5,2	8200	4320	845
MFR 3	540	30÷60	300÷700	600	3	3380	6	4,2	6200	3120	825
							7	4,7	7200	3720	845
							8	5,2	8200	4320	865
MFR 3,5	540	30÷60	300÷700	600	3,5	3880	6	4,2	6200	3120	865
							7	4,7	7200	3720	895
							8	5,2	8200	4320	915

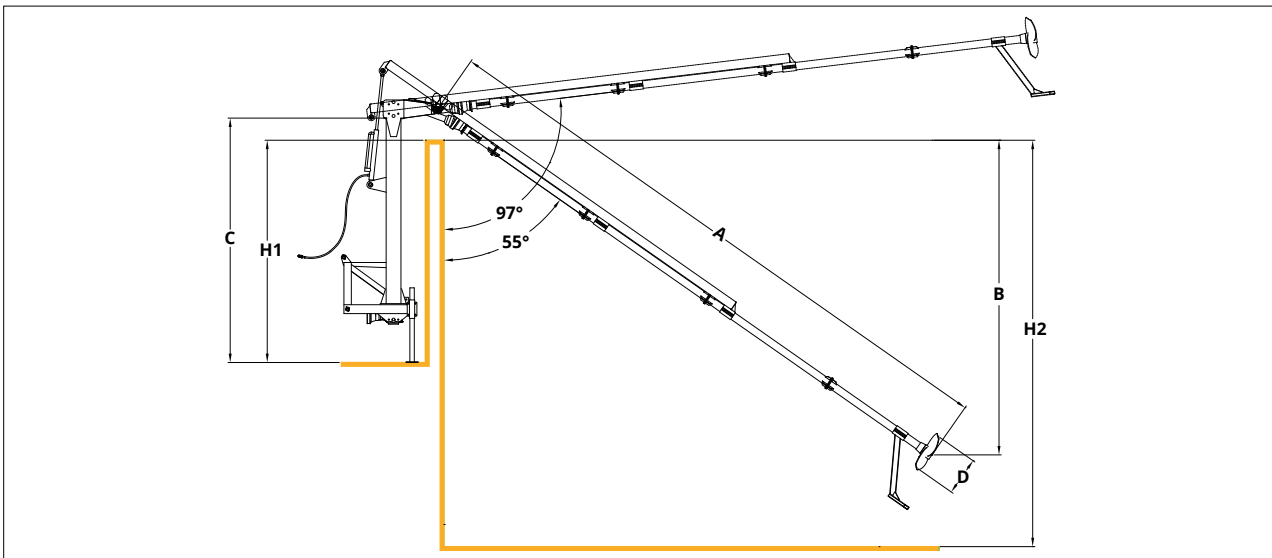

MLC

Pompa miscelatrice a trattore
Tractor driven mixing pump

La pompa miscelatrice MLC permette l'omogeneizzazione attraverso il sollevamento di grandi volumi di liquame in vasche sotto grigliato; offre elevate prestazioni sfruttando la forza motrice del trattore e grazie alla sua massiccia struttura garantisce un'estrema affidabilità, anche in presenza di liquami densi contenenti corpi solidi e fibrosi.

MLC mixing pump allows homogenization through lifting of large volumes of slurry in under-grate tanks; it offers high performance by exploiting tractor's power and thanks to its massive structure, it grants utmost reliability, even in the presence of thick sewage containing solid and fibrous matters.

CARATTERISTICHE | FEATURES

Modello Model	Giri/Min - RPM		P Max [kW]	Q [mc/h]	D [mm]	Telaio Frame [m]	H [m]	A [mm]	Peso Weight [kg]
	PTO	Pompa Pump							
MLC	540	750	55	2700	500	2,5	2	1800	740
						3	3	2300	800

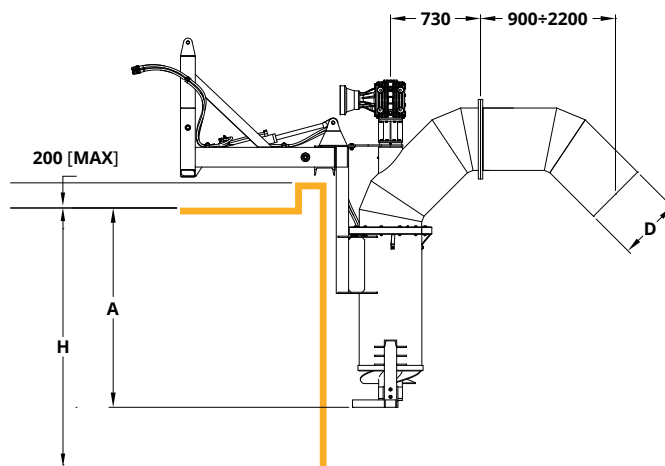

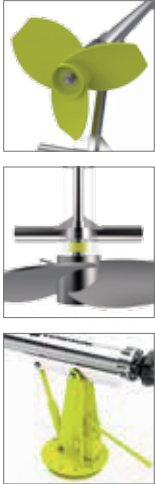

Il miscelatore MDE, azionato da motore elettrico, offre un'elevata efficienza e garantisce notevole praticità: l'installazione può avvenire sia in vasche interrata che sopraelevate; il funzionamento automatizzato agevola la gestione delle operazioni di miscelazione. Caratterizzato da una solida struttura in acciaio inossidabile, è composto da un braccio regolabile idraulicamente e da una colonna con ralla orientabile manualmente.

MDE mixer, driven by electric motor, offers high efficiency and grants great practicality; it can be installed both in underground and in above-ground tanks; automated operation facilitates the management of mixing operations. Characterized by a sturdy structure made of stainless steel, it is made up of a hydraulically adjustable arm and a manually adjustable column with slewing ring.

CARATTERISTICHE | FEATURES

Modello Model	Giri/Min RPM	P [kW]	Q [mc/h]	C [mm]	D [mm]	Braccio Arm [m]	H [m]	A [mm]	B Max [mm]	Peso Weight [kg]
MDE 4	1450	5,5	100+150	1100	600	4	2,5	3800	1500	420
		7,5	150+200	1100						
		11	200+250	1000						
MDE 5	1450	5,5	100+150	1100	600	5	3,5	4800	2200	480
		7,5	150+200	1100						
		11	200+250	1000						
		15	250+300	1000						
MDE 6	1450	18,5	300+350	1100	600	6	4	5800	2800	530
		7,5	150+200	1100						
		11	200+250	1300						
MDE 7	1450	15	250+300	1350	600	7	5	6800	3500	590
		18,5	300+350	1350						
		11	200+250	1300						
MDE 8	1450	15	250+300	1350	600	8	5,5	7800	4200	620
		18,5	300+350	1350						
		11	200+250	1300						
MDE 10	1450	18,5	300+350	1350	600	10	7	9800	5600	980

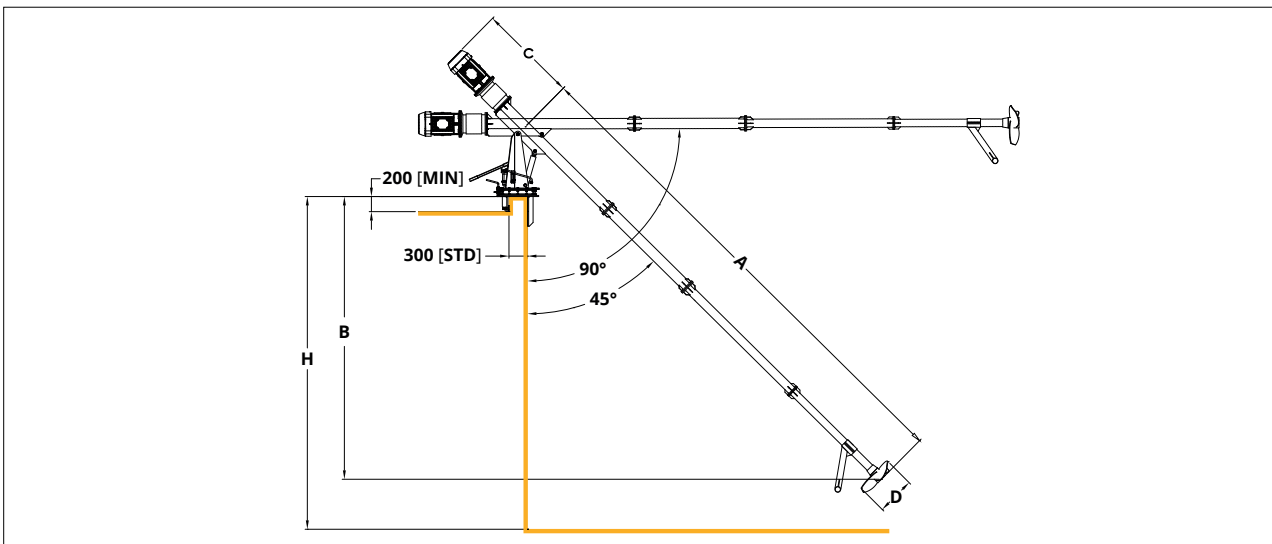

SISTEMI PER GESTIONE LIQUAMI

SEWAGE TREATMENT SYSTEMS

Grazie alla nostra capacità di progettazione e all'esperienza derivata dall'applicazione dei prodotti nelle varie installazioni, siamo in grado di analizzare le necessità del cliente e sviluppare su misura il sistema più adatto per la gestione dei liquami. Le caratteristiche tecniche e funzionali adatte alle difficili condizioni del settore zootecnico trovano applicazione anche in ambito industriale.

Thanks to our design skills and to the experience gained from the application of our products in many different installations, we are able to analyze the customer's needs and develop the most suitable tailor-made system for sewage treatment. The technical and functional features suitable for the difficult conditions of the zootechnical sector can also be applied to the industrial field.

Gestione dei reflui zootecnici

Zootechnical waste water treatment

- 1 | Sistema automatizzato per lavaggio pavimento sala d'attesa mungitura.**
Automated system for milking parlor's floor cleaning.
- 2 | Sistema manuale / automatizzato per il ricircolo dei liquami sotto grigliato.**
Manual / automated system for under-grate slurry recirculation.
- 3 | Sistema automatizzato per il ricircolo del canale collettore dei raschiatori.**
Automated system for scrapers' canal recirculation.
- 4 | Sistema manuale / automatizzato per la miscelazione delle vasche di raccolta.**
Manual / automated system for slurry mixing in collection tanks.
- 5 | Sistema manuale / automatizzato per il trasferimento dei liquami.**
Manual / automated system for slurry transfer.
- 6 | Sistema manuale / automatizzato per trasferimento e gestione dei reflui nell'impianto di biogas.**
Manual / automated system for waste water transfer and treatment in the biogas plant.
- 7 | Sistema automatizzato per la separazione dei reflui.**
Automated system for waste water separation.
- 8 | Sistema manuale / automatizzato per la miscelazione delle vasche di stoccaggio.**
Manual / automated system for slurry mixing in storage tanks.
- 9 | Sistema ombelicale per la distribuzione dei reflui.**
Umbilical system for slurry distribution.

La perfetta soluzione per ogni esigenza

Perfectly combined to meet all your needs



1



2



3



4



5



6



7



8



9

SISTEMA OMBELICALE

UMBILICAL SYSTEM



LKT

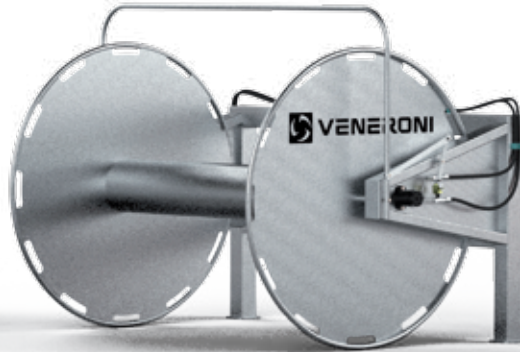

HWN



TDN

Prelevando i reflui dalle vasche di stoccaggio, la pompa LKT li immette nella rete di distribuzione interrata o direttamente nella manichetta. Quest'ultima, stesa lungo un confine dell'area di distribuzione con l'ausilio dell'avvolgitore e successivamente collegata alla testa di distribuzione, viene trainata percorrendo l'intera superficie, consentendo una distribuzione dei reflui rapida e uniforme, impiegando un'attrezzatura leggera.

After collection from the storage tanks, the LKT pump supplies slurry into the underground distribution network or directly into the hose. The latter, spread out along a side of the distribution area with the reel hose-coiler and then connected to the spreader, is pulled along the whole field, allowing a fast and uniform slurry distribution, using a lightweight equipment.



CARATTERISTICHE | FEATURES

Modello Model	D [mm]	A [mm]	B [m]	C [mm]	E [mm]	Peso Weight [kg]	Capacità Max Max Capacity [m] HOSE D 102
HWN 1000	1600	2520	2000	1660	1950	460	1000

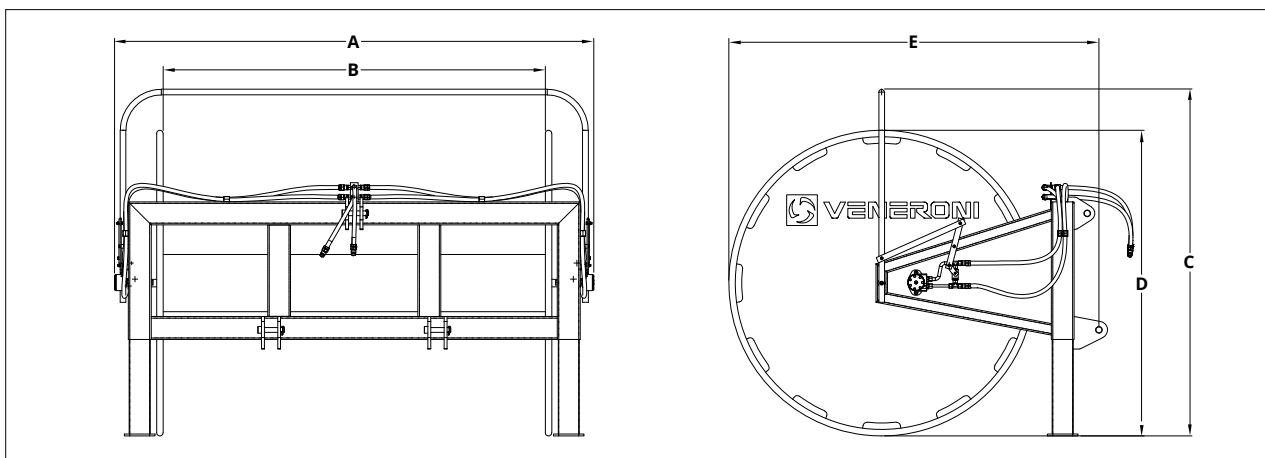

TDN | Testa di distribuzione
Spreader

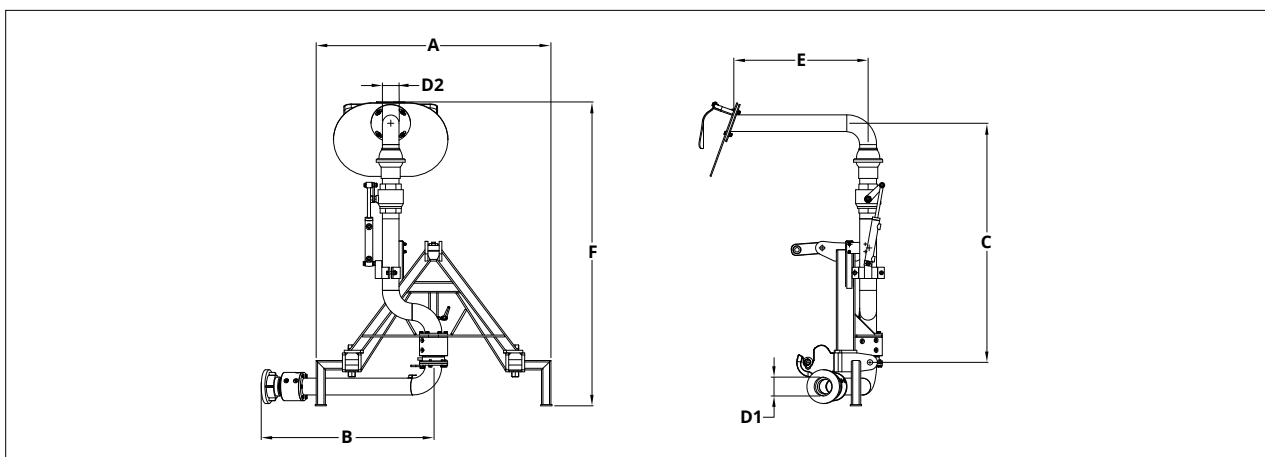

CARATTERISTICHE | FEATURES

Modello Model	D1 [mm]	D2 [mm]	A [m]	B [mm]	C [mm]	E [mm]	F [mm]	Peso Weight [kg]
TDN	STORZ 133	90	1260	925	1290	745	1650	165



HILCOFLEX | Manichetta in poliuretano
Polyurethane hose

CARATTERISTICHE | FEATURES

Modello Model	D [mm]	Pressione di lavoro Working pressure [bar]	Carico di rottura Max Max Breaking strenght [kg]
HILCOFLEX PU 	102 - 4"	17	13800
	127 - 5"	17	17000
HILCOFLEX PU DRAG 	102 - 4"	17	13800
	127 - 5"	17	20500

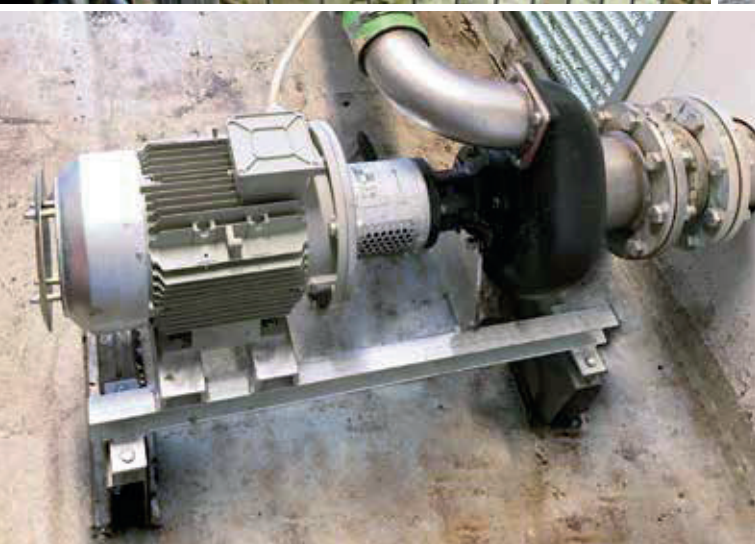
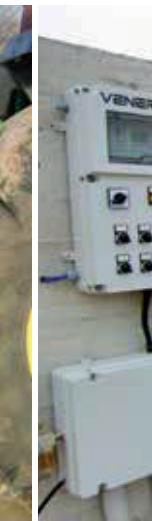
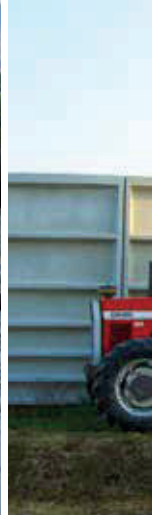



WIDE FLUID MOTION

LAND FLUID MOTION

■ **RAW** FLUID MOTION



Spinti dal flusso della passione dal 1957

Driven by the flow of passion since 1957

VENERONI srl
Via della Resistenza, 8
26020 Formigara (CR) - Italy
Tel. +39 0374 78036
Fax +39 0374 78314
info@veneroni.it
www.veneroni.it

